

4	5	6
发行版本 Revision	修改内容 Description	制图 Drawing
A / 0	First release	Ding
		日期 Date
		2023.06.02

Pin Assignment  
(Front View)

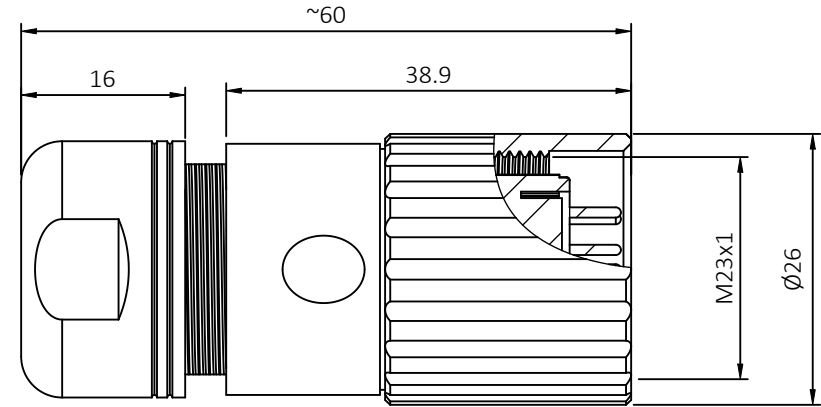
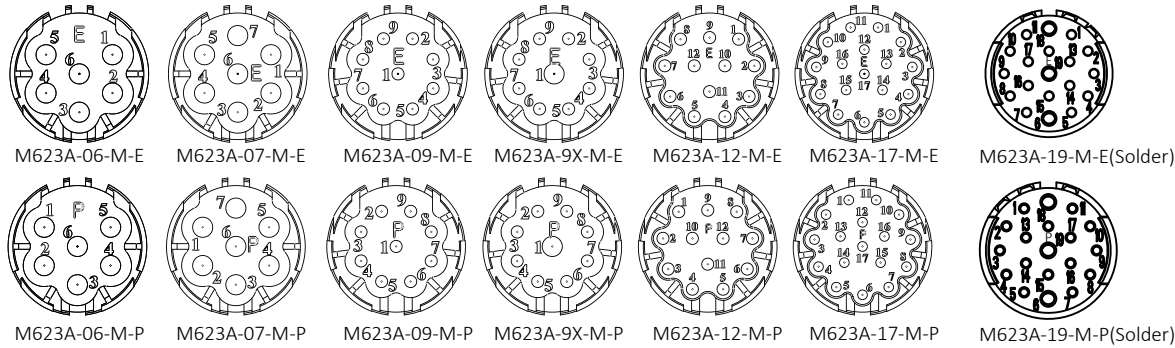

Technology parameter:

P/N	M623A-06-M	M623A-07-M	M623A-09-M	M623A-9X-M	M623A-12-M	M623A-17-M	M623A-19-M
NO.of contacts	6	7	9	9X	12	17	19
Rated current/voltage	20A/300V	20A/300V	8A/300V	8A/260V 20A/300V	8A/260V	8A/260V	8A/125V 20A/200V
Operation limit voltage(AC.V.rms)	250	250	200	200	200	200	200
Withstanding voltage (AC.V.rms) 1 minute	2500	2500	2500	2500	2500	2500	2500
Insulation resistance	≥100MΩ	≥100MΩ	≥100MΩ	≥100MΩ	≥100MΩ	≥100MΩ	≥100MΩ
Contact resistance	≤5mΩ	≤5mΩ	≤5mΩ	≤5mΩ	≤5mΩ	≤5mΩ	≤5mΩ
Cup mouth aperture	Ø2.4	Ø2.4	Ø1.3	Ø1.3 Ø2.4	Ø1.3	Ø1.3	Ø1.3
Contact diameter	Ø2	Ø2	Ø1	Ø1*8 Ø2*1	Ø1	Ø1	Ø1*16 Ø1.5*3

Material and specifications:

1. Coupling: Threaded coupling
2. Shell material: Zinc alloy with nickelplate
3. Insert material: PA66+GF
4. Contact material: copper, gold-plated
5. Termination: Crimp(19P is Solder)
6. Mating cycle: >500 cycles
7. Temperature range: -25°C~+85°C
8. Cable diameter: Ø5mm~Ø10mm

客户料号 Cus' P/N		图号 File No.	M623A-xx-M-E/P	品名 Name	M23 Male connector ,Crimp type
未注公差 Unless Otherwise Specified		单位 Unit	mm	版本 Revision	A/0
线性 Linear	0.5~6	±0.1	比例 Scale		图纸确认 APPROVAL
	>6~30	±0.2			日期 Date
角度 Angles	±3°		页码 Page	1/1	审核 Checked Jim 客户确认 Customer Approved
					2023.06.02
					2023.06.02